

WHERE TO MOUNT

Mount lock 1 to 2 feet from rear edge of awning. If possible, catch portion should be attached to rib of coach (Fig.1). Note: If the awning rests on the glass and available space is limited to less than 1', the latch should be mounted as close to the window as possible.

LOCATE LOOP

Remove the paper from one side of the double sided tape and affix it to the flat bottom surface of the loop. Slip the hook through the loop to create the lock assembly. Place lock assembly in proposed location so that hook fits flat against case and loop is flat against coach, as far down as possible. (Fig.2).

Remove the backing from the tape on the bottom of the loop and stick the loop to the coach in the position determined above. Drill #8 holes and use the silicone and 3/16 x 1" expanding rivets to attach the loop to the coach.

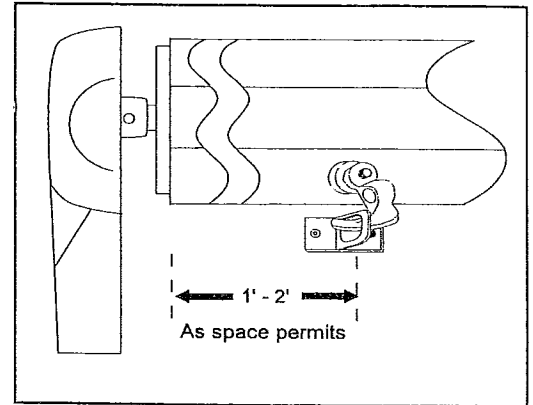

Fig. 1

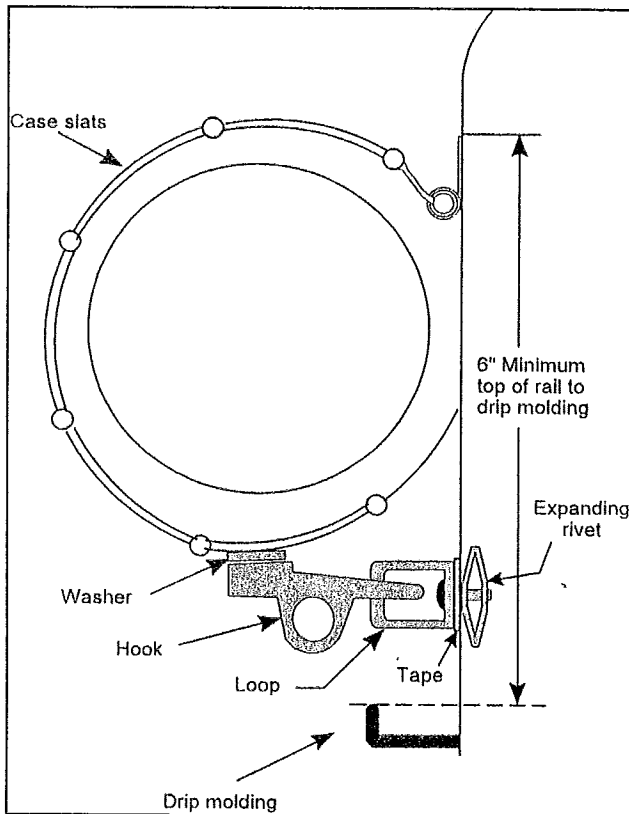

Figure 2

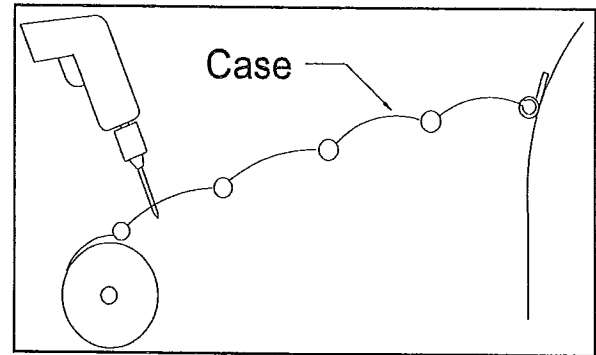

Figure 3

LOCATE HOOK

Place the hook through the loop, pull firmly against loop and mark its location on the case through swivel hole in hook. Partially open awning and drill #8 hole through case (Fig.3). Apply Loctite to threads of 10-32 screw and insert from the underside of the case with the small nylon washer between the head of the screw and the case and the large washer between the hook and the case (Fig.4). Tighten screw until latch is difficult to turn by hand.

HOW TO USE

Insert the awning pull hook into the eye of the Travel Latch and rotate latch to lock or unlock position. Check occasionally that latch is tight. If latch turns freely, tighten screw until latch is difficult to turn by hand.

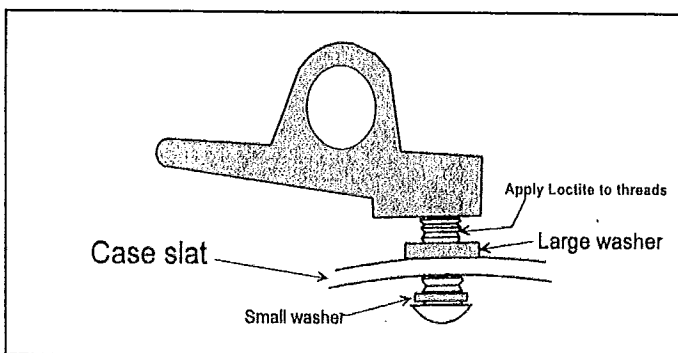
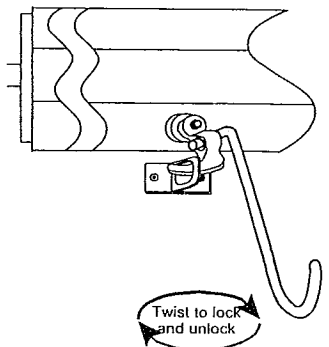

Fig. 4

REPLACING OLDER STYLE LATCH

Remove old latch by drilling out the rivet. Drill existing hole to #8. Follow installation instructions above.