

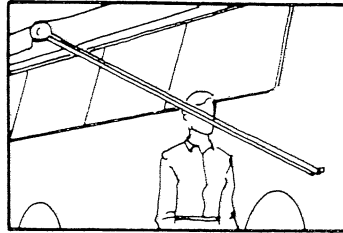

SLIDER BAR INSTALLATION INSTRUCTIONS

Zip-Dee Slide Bar adjusts height of awning to allow any person to walk under awning support arm without hitting it or having to duck under it.



Before Slide Bar

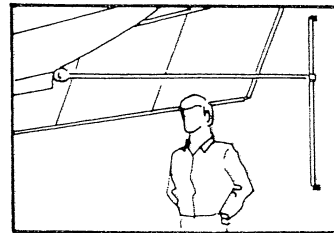

After Slide Bar

*Note: The Slide Bar may be installed on either or both arms of awning (standard package is set of 2 arms). Instructions show installation on front arm of awning for example only.

1. Open awning and set rafter arms to stabilize. Do not lock Z-lock. Support roller tube and unbolt main arm from Hinge casting (3/8" wrench). Swing arm to vertical position and rest on ground.

main arm

Slide Hinge

2. Slip a Slide Hinge onto one of the bars, positioning the snap stud on the same side as the large receiving hole.

3. Attach either end of Slide Bar to Hinge casting on vehicle, positioning slide hinge so that snap stud is pointing away from awning and flanges are facing forward. Secure with bolt and cap nut removed in step 1.

4. Attach a Vertical Hinge casting (flange downward) to the free end of the bar with a 1 5/8" bolt and a cap nut. Lift the arm up toward the vehicle and mark 2 sides of the casting on the vehicle, as shown.

1" sheet metal screws

Standard adjustment range-24"

5. Drill through with 1/4" bit. Fill hole with silicone sealant and attach Hinge to vehicle with 1" sheet metal screws.

1 1/2" bolt

6. Attach Main Arm to Slide Hinge with 1 1/2" bolt provided. Secure with cap nut.

7. Repeat for opposite arm, if 2 sliders are being installed

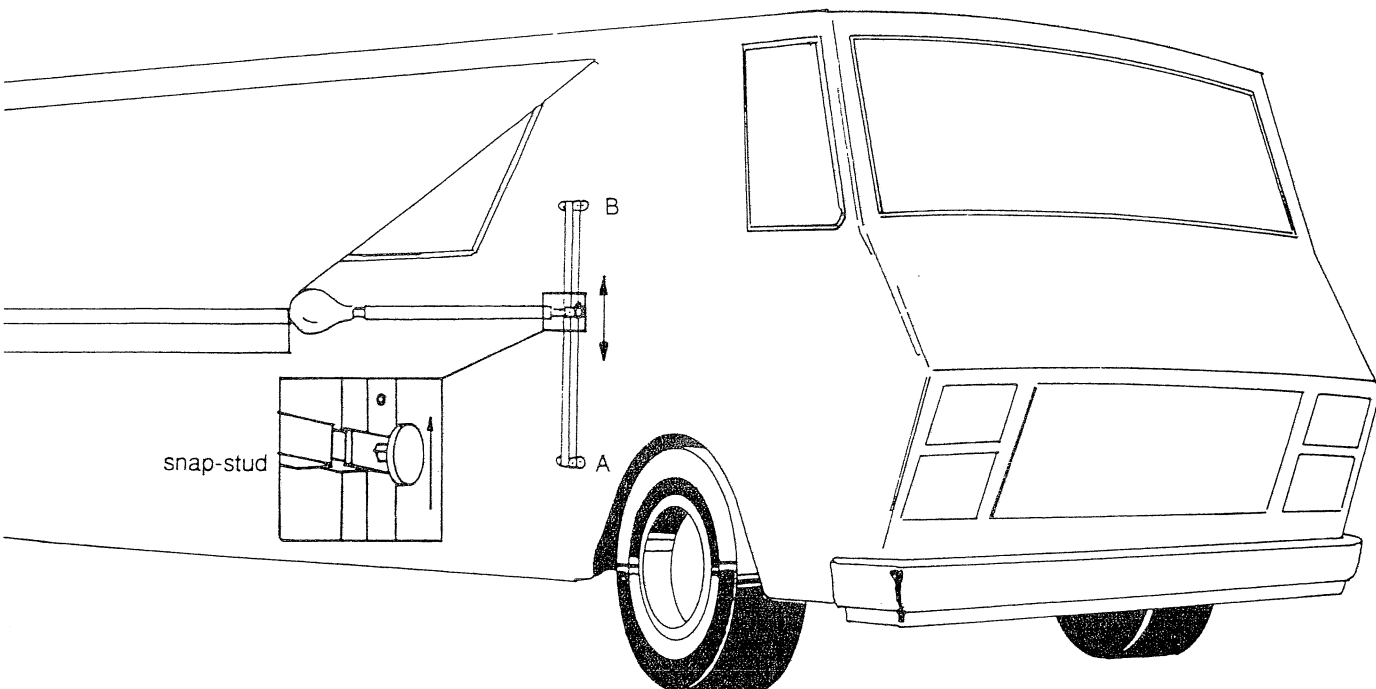
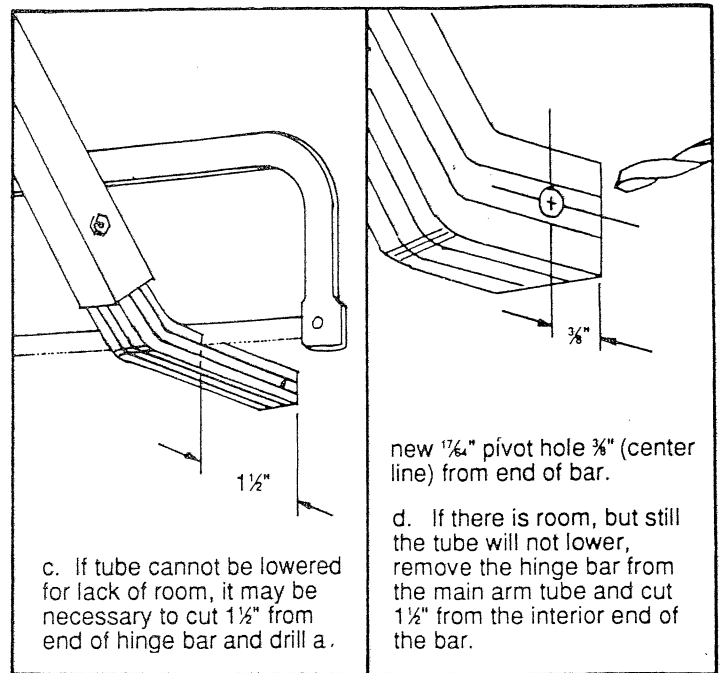
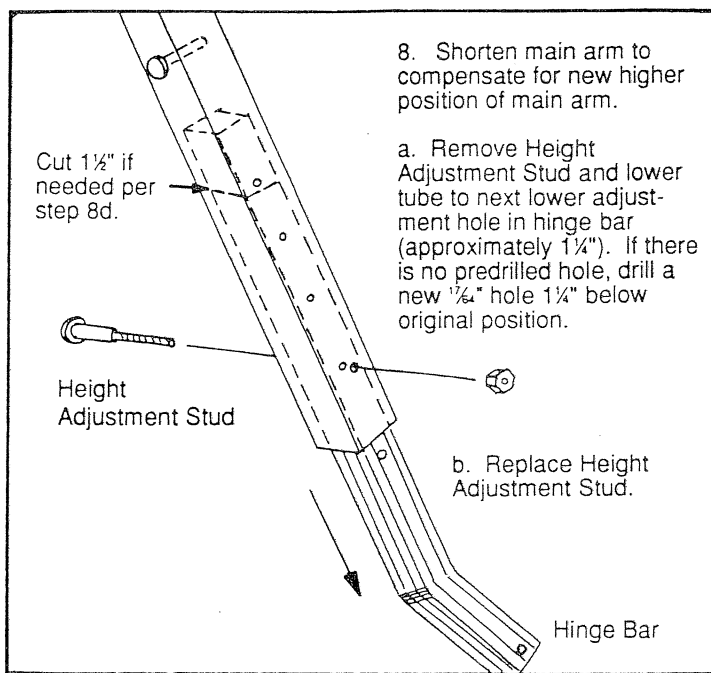

Tools required:

1. Two 3/8" open, box or socket wrenches.
2. Hand drill with 1/8", 1/16" bits.
3. #3 Phillips screw driver.
4. Silicone sealer.
5. Hack saw.

Materials supplied with Slide Bar assembly:

1. (2) Slide Bar.
2. (2) Slide hinge and snap assembly.
3. (2) Hinge casting.
4. (4) Cap nut.
5. (2) 1 1/8" bolt.
6. (2) 1 1/2" bolt.
7. (4) 1" sheet metal screws.

For proper operation of Slide Bar:

1. Release Z-lock, open awning and set rafter arms in place. **Do not close Z-lock lever.**

2. Pull snap-stud and lift main arm, sliding from position A up to position B, allowing snap-stud to engage in receiving hole.

3. To restore awning to travel position (A), reverse process.